

DC HIGH VOLTAGE EV RELAY

EVD30



EVD30

PERFORMANCE

ITEM		PARAMETER			
Contact Arrangement		SPST-NO			
Auxiliary Contact		--			
Voltage Rating		12-200Vdc	12-750Vdc	12-1000Vdc	12-1500Vdc
Current Rating		1-30A			
Current Endurance		30A Cont. ; 100A 10min. ; 150A 180sec. ; 200A 50sec.			
Break Current, Max (only 1 time)		300A 320Vdc			
Contact Resistance (Initial)		≤1mΩ (at 30A)			
Operate Time (at 20°C)		30ms Max.			
Bounce Time (at 20°C)		5ms Max.			
Release Time (at 20°C)		10ms Max.			
Mechanical Life (0.5s:0.5s)		2×10 ⁵ 次			
Electrical Life		See graph			
Current-carrying capacity curve		See graph			
Insulation resistance		Initial: 100MΩ 1000Vdc After test: 50MΩ 1000Vdc			
Impulse withstand voltage (initial)	Main contact 1mA/1min.(sea level)	AC 3500Vrms			
	Main contact & coil 1mA/1min.(sea level)	AC 2500Vrms	AC 3500Vrms		
Mechanical performance	Shock	20G peak,11ms 1/2 Sine wave (coil energized)			
	Vibration	20G peak,80-2000Hz,Sine wave (coil energized)			
	Strength	50G acceleration, half sine wave impulse 6ms, 50 times per axis.			
Operating & Storage Condition	Ambient Temperature	-40~+85°C			
	Humidity	5~95% RH.			
Altitude		≤4000m			
Weight		approx. 115g			
Certification		UL、CE、CCC			

COIL DATA

Coil Type	Nominal voltage (at 20°C)	Pick-up voltage (at 20°C)	Drop-out voltage (at 20°C)	Coil resistance (at 20°C)	Holding power (at 20°C)	Coil polarity
Single-coil	12Vdc	≤9Vdc	≥1Vdc	40Ω×(1±7%)	approx. 3.6W	non-polarized
	24Vdc	≤18Vdc	≥2Vdc	152Ω×(1±7%)	approx. 3.8W	non-polarized

EVD30

DC HIGH VOLTAGE EV RELAY

EVD30



PART CODE



DIMENSIONS

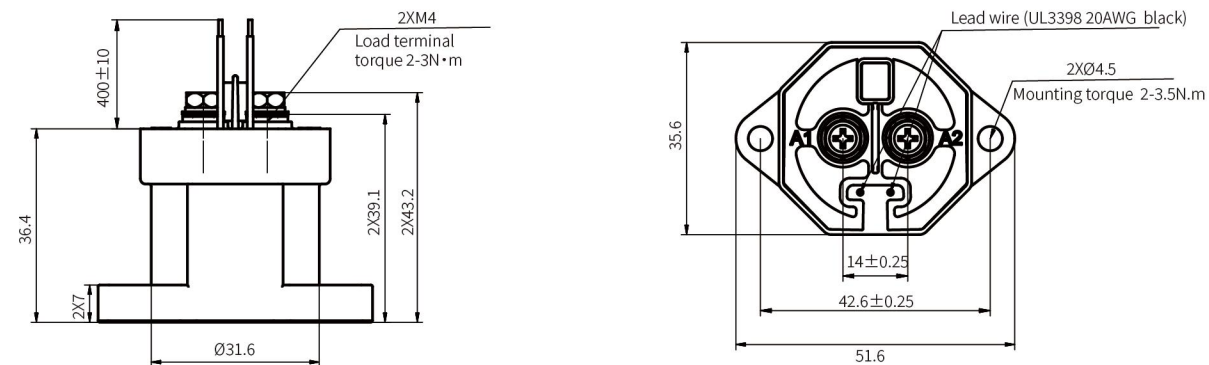

Note: 1.fastener:2xM4x8mm; 2.Mounting hardware M 4, torque 2-3.5N·m;
3.Main contact hardware M 4, torque 2-3N·m; 4.Main contact to copper area≥6mm²;

GRAPHS

